

SPECIFICATIONS

12M

Model	Inside length	Inside width	Side height	Tailgate height	CAPACITIES			App. weight
					Water level	Front lift hoist	Side tilt cylinders	
TCB-9-T-AL-S-LF	9'	88"	27"	39"	5.5 cu. yd.	20 tons	19 tons	4360 lb.
TCB-10-T-AL-S-LF	10'	88"	27"	39"	6.11 cu. yd.	20 tons	19 tons	4860 lb.
TCB-11-T-AL-S-LF	11'	88"	27"	39"	6.72 cu. yd.	30 tons	19 tons	5360 lb.
TCB-12-T-AH-S-LF	12'	88"	39"	51"	10.59 cu. yd.	30 tons	19 tons	5880 lb.
TCB-13-T-AH-S-LF	13'	88"	39"	51"	11.47 cu. yd.	35 tons	19 tons	6300 lb.
TCB-14-T-AH-S-LF	14'	88"	39"	51"	12.35 cu. yd.	35 tons	19 tons	6670 lb.
TCB-14-T-AL-S-LF Low Profile	14'	88"	27"	39"	8.5 cu. yd.	35 tons	19 tons	6370 lb.

OPTIONS

- Sides and front panel 180,000 PSI yield strength steel
- Aluminum tailgate
- Summer chute
- Coal chute door (1, 2 or 3 as needed)
- Screens
- Bolt-on rear apron
- Pre-wetting system
- Electronic spreader control
- Special paint
- Hydraulically actuated discharge chute
- Rear tailgate lateral opening (barn door)
- Lights in rear corner posts
- Extended greasing points on floor hinge(3 or 4)
- Sides, front panel and tailgate constructed from 304 stainless steel

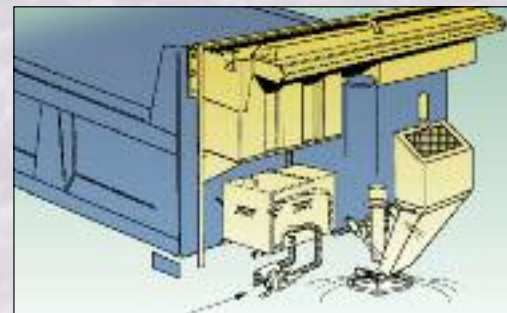

Pre-wetting system

- Pre-wetting system specifically designed for attachment to most makes of side tilt bodies
- 160 US gallons (600 litres) tank is conveniently located below the cab shield



12 M COMBINATION DUMP BODY/ SPREADER

- Versatile • Reliable
- Multiple applications
- Innovative

*Now Available
with optional 304
stainless steel sides,
front panel and
tailgate*



OFTEN IMITATED...

But never equalled!



At Tenco Machinery (CDN) Ltd, our policy is to meet the highest quality standards. In order to improve our products, changes in design or alterations might occur. It will in no way alter quality or efficiency of our equipment.



Tenco Machinery (CDN) Ltd *Trade mark of / Marque de commerce de Les Machineries Tenco (CDN) Ltée.
Tenco Machinery (CDN) Ltd quality system certified ISO 9001-2000.
Tenco Machinery (CDN) Ltd is now the exclusive authorised user of the Vohl® trade mark for snowblowers and sweepers.

Distributed by:

Tenco Machinery (CDN) Ltd.
1318, Principale
St-Valérien-de-Milton, Québec
Canada J0H 2B0
Telephone: (450) 549-2411
Fax: (450) 549-2410
E-mail: mktg@tenco.ca
Website: www.tenco.ca

Tenco USA Inc.
5700 S. Lima Road
Lakeville, New York
14480-0635
Telephone: (585) 346-3040
Fax: (585) 346-2982
E-mail: brian@tencousa.com
Website: www.tencousa.com

Plamondon Camquip Ltée
1116, Durance
Charlesbourg, Québec
G2N 1X2
Telephone: (418) 849-7575
Fax: (418) 849-4632
(branch in Chicoutimi, QC)
E-mail: amarchand@tenco.ca

Tenco New England Inc.
450 N. Main Street
Barre, VT 05641
Telephone: (800) 451-5014
Fax: (802) 476-1003
(branch in Berwick, ME)
E-mail: mikem@tenco-newengland.com
Website: www.tenco-newengland.com

LITHO CANADA TCB-529-AN-08

BENEFITS/FEATURES

THE 12M IS DESIGNED AND CONSTRUCTED TO WITHSTAND THE MOST ARDUOUS TASKS

Front lift telescopic hoist utilises nitrated piston rods for corrosion resistance and longer life

Tenelene chute

Discharge's material at front driver's side through a single conveyor chain
Eliminates the necessity for a second conveyor system



Spinner location provides superior traction and better spreading pattern

Function as a dump body year round

Vertical reinforcements on side panels

25:1 gear box includes a built-in speed sensor

Easily adjustable urethane spinner disc

• Optional cross conveyor for front left, right or combination left and right material discharge

STANDARDS

Full width tailgate enables complete dump body functions

Floor and conveyor cover is constructed from 3/16" thick 180,000 PSI yield strength steel

Honeycomb type floor under structure creates a material shedding design

Floor strength ensures an even lift from side tilt cylinders
Eliminates the necessity of a 50/50 flow divider

Six (6) panel tailgate includes 3/16" thick 180,000 PSI yield strength steel plate

Hinged conveyor cover remains with body at all times



Side tilt cylinders are treated with an ARCOR-N nitration process

• The piston rods include a Corolac polymer impregnation for increase durability

*A feature exclusive only to Tenco

• The rods have been salt bath tested for 1000 hours with no sign of corrosion

Long members of 10" "I" beam @ 25.4 lb./ft

Floor rotates on 1 3/4" hard induction chromed hinge shaft for superior strength

Bolt-on floor hinges with 3 greasing points on single axle, 4 greasing points on tandem axle

Tenco's design eliminates the requirement and added weight of a stationary panel on right side

LOW CENTER OF GRAVITY

Load is substantially diminished before requiring activation of side tilt mechanism

HUSKY SERIES COMBINATION DUMP BODY/SPREADER

- Available in 8', 9' and 10' inside body lengths – standard steel or stainless steel construction.
- Designed for installation onto chassis ranging from one (1) ton pick-up to the low-pro class.



Full capacity of body is utilized

Rapidly convert from dump to spread mode by adjusting hinged conveyor cover

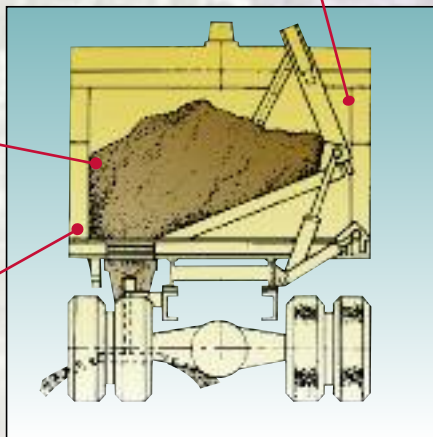

MAINTENANCE INNOVATIONS

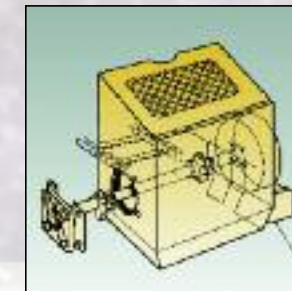

Slotted front discharge system allows gearbox, sprockets, bearings and shaft to be easily removed

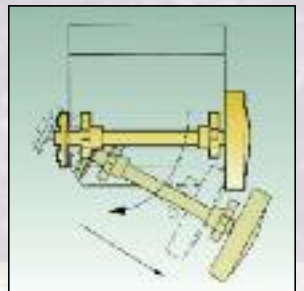

Chain tension adjustment through two (2) grease cylinders

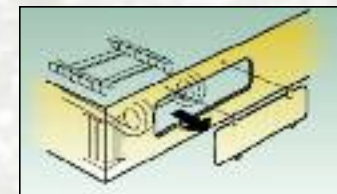

Opening in rear apron permits quick access to the chain, chain adjusters, shaft and sprockets

